

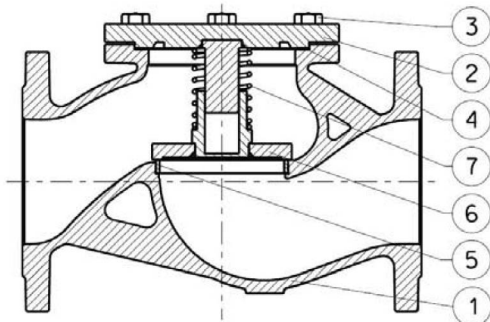

INSTALLATION

Before to assemble the valve at the pipeline check inside the body to be completely clean, possible impurities have to be removed in order to ensure a right functioning. If compressed air is at your disposal, use it for a better cleaning. The counter-flanges of the pipeline must be parallel and have aligned holes. Check the space between them, keeping into account the gaskets and their flatter after bolts closing (it should not be too much or too little) and face to face tolerances as per EN 558-1 standard. In case of limited pressures, ask for springs with reduced thrust, indicating the working pressure. The valve must be assembled following the direction indicated by the arrow on the body. Fix the valve in the right position at the pipeline and remember to insert the gaskets between the flanges centring them as much as possible on the raised faces. The raised faces have to be clean to allow a correct tightness. Fit the bolts in flanges holes and tighten them maintaining a diametrically opposed sequence (for a better deformation of the gaskets).



SERVICE APPLICATIONS

- Steam Boiler TRD 108/110
- Thermal oil transfer application DIN 4754
- Pressure vessel equipment TRB 801 No.45
- Hot water systems DIN 4752
- Powerstations
- Processing technology
- Vacuum facilities
- Gas supply
- Flue gas purification plant
- Cooling and freezing systems
- Ammonia
- Vapour

MAINTENANCE

The sole possible leakage is the non-sealing of the seat normally due to the wear of time or to possible extraneous matters in the pipeline. To restore the sealing disassemble the valve : loosen the screws (3), take off the cover (2), check the seats condition; if it is still integral , carefully clean it as well as the sliding parts of the disc, of the guide-pin and of the spring (7), If the spring is damaged, replace it. If necessary the valve can be completely disassembled using standard tools. Before to assemble it again, check if the sealing seats are carefully clean and not damaged; check if each part of the gasket is integral, ortherwise it is recommended to replace them.

MATERIALS

NO.	PART NAME	MATERIAL
1	Body	1.0619 Cast Steel
2	Cover	Carbon Steel
3	Screws	Steel B7/2H
4	Gasket	Graphite + ST. Steel
5	Seat	Stainless Steel
6	Disc	Steel+ST. Steel
7	Spring	ST. Steel



FUNCTIONING

The valve works both horizontally and vertically but if the flow raise the disc. In case of vertical installations, exclude the assembling with the flow direction from top to bottom; in case of horizontal installation, keep the cover upwards.

STANDARD EXECUTION

Cast steel body. Carbon steel cover. St. steel spring. Stainless steel sealing seats and disc. Graphite + stainless steel gasket. Connection flanges dressed and drilled according to EN 1092-2 PN 40 with raised face.

WORKING CONDITIONS

DIN EN 1092-2

DN Size (mm)	Allowable pressure (bar)	Max working temperature related to the pressure
15-400	25	-10°C/+120°C
15-400	23	+200°C
15-400	21.8	+250°C
15-400	20	+300°C
15-400	17.5	+350°C
15-400	13.9	+450°C

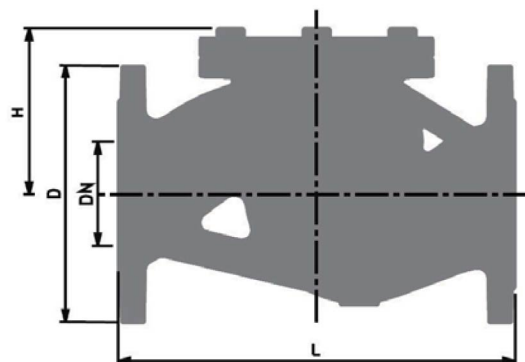

DIMENSIONS (mm)

Face to face DIN 3202 F1 (EN 558-1), Flange DIN 2501/2526

DN	D	L	H	Kg	Kvs
115	95	130	70	3.8	3.9
20	105	150	70	4.9	6.8
25	115	160	80	5.9	11.0
32	140	180	80	7.1	18.0
40	150	200	85	10.4	27.0
50	165	230	95	12.3	43.0
65	185	290	110	22.7	71.0
80	200	310	130	28.5	111.0
100	235	350	155	40.0	173.0
125	270	400	165	64.0	265.0
150	300	480	215	90.0	377.0
200	375	600	285	170.0	667.0
250	450	730	325	240.0	1053.0
300	515	850	365	374.0	1504.0
350	580	980	440	508	2042.0
400	660	1100	630	786	2725.0