

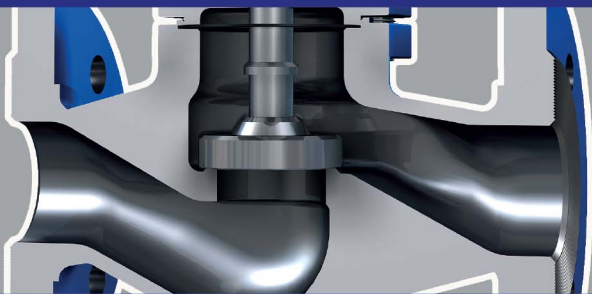

**WIKATÜREN**



# PLUS SERIES

Bellows Sealed Globe Valves

USERS MANUAL

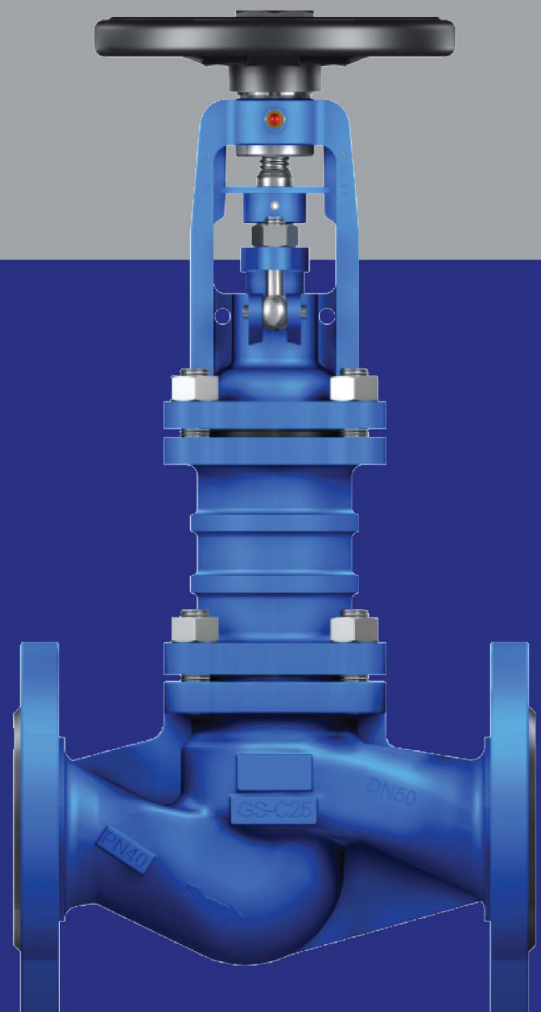

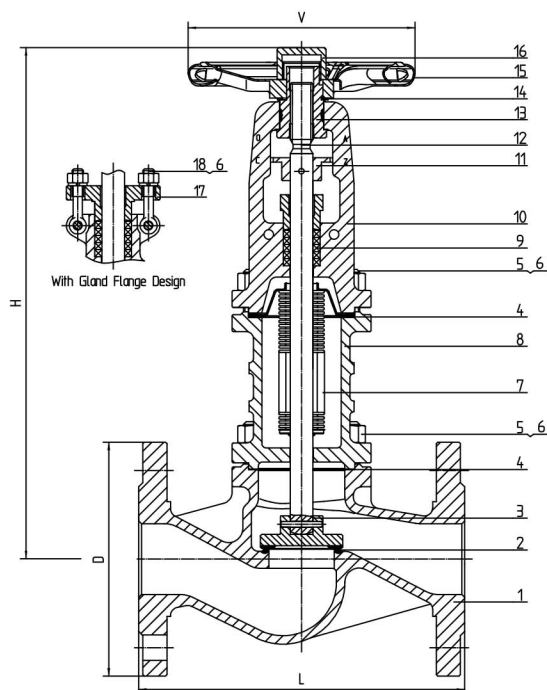

**CONTENTS**

1. Product description
2. Requirement for maintenance staff
3. Transport and storage
4. Function
5. Application
6. Assembly
7. Maintenance
8. Service and repair
9. Reasons of operating disturbances and remedy
10. Valve service discontinuity
11. Warranty terms

**1. PRODUCT DESCRIPTION**

Bellow sealed globe valves are manufactured at different executions, they are used as stop valves and throttling valves. Stop valves are designed only for shut off and open the flow, throttling valves are designed for flow control. Stem sealing is performed by flexible bellow and additional protecting gland.

NO.	PART NAME	MATERIAL		
1	Body	1.0619	1.4308	1.4408
2	Seat Surface	X20Cr13	1.4308	1.4408
3	Disc Seat Surface	X20Cr13	1.4308	1.4408
3.1	Screw	X20Cr13	1.4308	1.4408
3.2	Guide Disc	C22.8+X20Cr13	1.4301	1.4401
3.3	Disc	C22.8+X20Cr13	1.4301	1.4401
3.4	Disc Screw	X20Cr13	1.4301	1.4401
4	Gasket	SS304+Graphite	SS304+Graphite	SS304+Graphite
5	Nuts	ASTM A194 2H	ASTM A320 8	ASTM A320 8
6	Bolts	ASTM A193 B7	ASTM A320 B8	ASTM A320 B8
7	Bellows	SS316L	SS316L	SS316L
8	Bonnet	1.0619	1.4308	1.4408
9	Packing	Graphite	Graphite	Graphite
10	Yoke	1.0619	1.4308	1.4408
11	No Rot Device	X20Cr13	1.4301	1.4301
12	Stem	X20Cr13	1.4301	1.4401
13	Yoke Nut	GGG40.3	Cu-Alloy	Cu-Alloy
14	Circlip	65Mn	65Mn	65Mn
15	Handwheel	Steel	Steel	Steel
16	Lock Nut	C.S	C.S	C.S
17	Gland Flange	1.0619	1.4308	1.4308
18	Eye Bolts	ASTM A193 B7	ASTM A320 B8	ASTM A320 B8

Bellow sealed valves are provided with casted marking according to requirements of PN-EN19 standard. The marking facilitates technical identification and contains:

- Nominal diameter DN (mm),
- Nominal pressure PN (bar),
- Body and bonnet material marking,
- Arrow indicating medium flow direction,
- Manufacturer marking,
- Heat number,
- CE marking, for valves subjected 2014/68/UE directive. CE marking starts from DN32

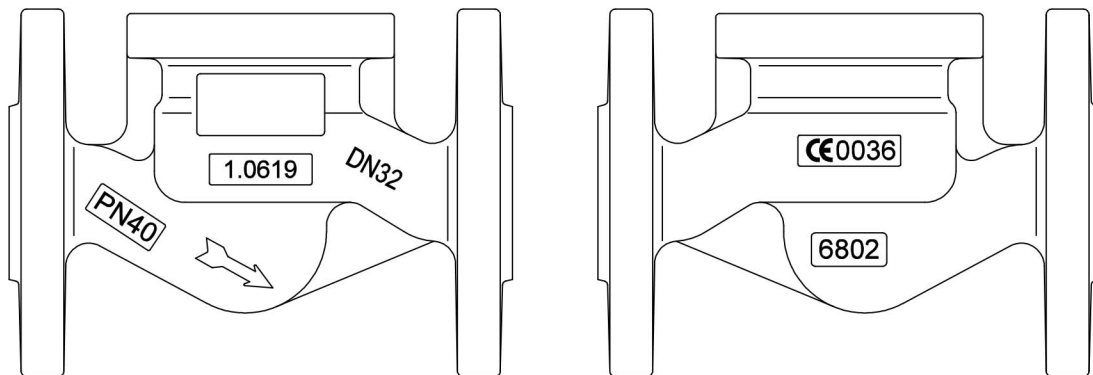

## 2. REQUIREMENTS FOR MAINTENANCE STAFF

The staff assigned to assembly, operating and maintenance tasks should be qualified to carry out such jobs. If the valve is provided with mechanical actuators, operating manual of actuator should be obeyed. If during valve operation heat parts of the valve, for example handwheel, body or bonnet parts could cause burn, user is obliged to protect them against touch.

## 3. TRANSPORT AND STORAGE

Transport and storage should be carried out at temperature from -20°C to 65°C, and valves should be protected against external forces influence and destruction of painting layer as well. The aim of painting layer is to protect the valves against rust during transport and storage. Valves should be kept at unpolluted rooms and they should be also protected against influence of atmospheric conditions. There should be applied drying agent or heating at damp rooms in order to prevent condensate formation. The valves should be transported in such a way to avoid handwheel and valve stem damage.



### 4. FUNCTION

Valves with stop disc are designed for shut off medium flow, valves with throttling disc enable to control the flow.

### 5. APPLICATION

- Industry
- Heating
- Refrigeration and air conditioning
- Hot and cold industrial water
- Industrial oils
- Steam
- Compressed air
- Neutral fluids - gases and liquids of group 1 and 2 according to Regulation EC No 1272/2008 resulting from the practice of using.

The kind of working medium makes some materials to be use or to be prohibited for use. Valves were designed for normal working conditions. In the case that working conditions exceed these requirements (for example for aggressive or abrasive medium) user should ask manufacturer before placing an order. When selecting the valve for specific medium, "List of Chemical Resistance" can be helpful. It can be found at manufacturer website near catalogue cards.

Working pressure should be adapted to maximum medium temperature according to the table as below.

PRESSURE-TEMPERATURE RATINGS ACC to EN 1092-1								
NOM PRESSURE (PN)	MATERIAL	WORKING PRESSURE AT TEMPERATURES °C						
		100°C	150°C	200°C	250°C	300°C	350°C	400°C
PN16	1.0619 GP240GH	14.8 Bar	14.0 Bar	13.3 Bar	12.1 Bar	11.0 Bar	10.2 Bar	9.5 Bar
PN25		23.2 Bar	22.0 Bar	20.8 Bar	19.0 Bar	17.2 Bar	16.0 Bar	14.8 Bar
PN40		37.1 Bar	35.2 Bar	33.3 Bar	30.4 Bar	27.6 Bar	25.7 Bar	23.8 Bar



**Valves made of cast steel 1.0619 & GP240GH working at temperatures above 400°C can not operate for more than 100,000 hours because of the creep of a material.**

### 6. ASSEMBLY

During the assembly of bellow valves following rules should be observed:

- To evaluate before an assembly if the valves were not damaged during the transport or storage and to make sure that applied valves are suitable for working conditions and medium used in the plant,
- To take off dust caps if the valves are provided with them,
- To protect the valves during welding jobs against splinters and used plastics against excessive temperature,
- Steam pipelines should be fitted in such a way to avoid condensate collection; in order to avoid water hammer steam trap should be applied.



Pipeline where the valves are fitted should be conducted and assembled in such a way that the valve body is not subjected to bending moment and stretching forces.

Bolted joints on the pipeline must not cause additional stress resulted from excessive tightening, and fastener materials must comply with working conditions of the plant,

- During pipeline painting valve stem should be protected,
- Valves can be assembled in any position, however it is recommended to install the valve with handwheel upwards,



It should be take note of medium flow direction, marked with an arrow on the body and flow direction should be according to the arrow.

- Before plant startup, especially after repairs carried out, flash out the pipeline through entirely open valve, in order to avoid solid particles or welding splinters which may be harmful for sealing surfaces.
- Strainer (wire mesh filter) installed before the valve increases certainty of its correct action.
- During valve operation, hot parts of the valve, such as parts of the hull, may cause burns. User should place insulation shields and warning signs, if necessary.
- **Plant designer, contractor and user are responsible for valve selection suitable for working conditions.**

The valves have been designed for applications independent to external conditions. Where it exists danger on corrosion caused by external conditions (weather, aggressive gases, gases, etc.), corrosion protection or special arrangements with the manufacturer are recommended.



The 1.0619 & GP240GH carbon steel valves must not be installed as the final pipeline component if the valve temperature is less than 10°C or higher than 400 °C.

## 7. MAINTENANCE

During maintenance following rules should be observed:

- Start up process - sudden changes of pressure and temperature should be avoided when starting the plant,
- Valve is closed by turning the handwheel clockwise when looking from above the handwheel (according to arrow direction marked on the handwheel),
- Valve is opened by turning the handwheel counter-clockwise.





**It is prohibited to use additional lever when turning the handwheel**

- Performance of fitted valves can be checked by multiple closing and opening,
- If leakage on stem occurs in valves, it is necessary to tighten with moderate force two T-bolt nuts pressing the packing gland until the leakage disappear.

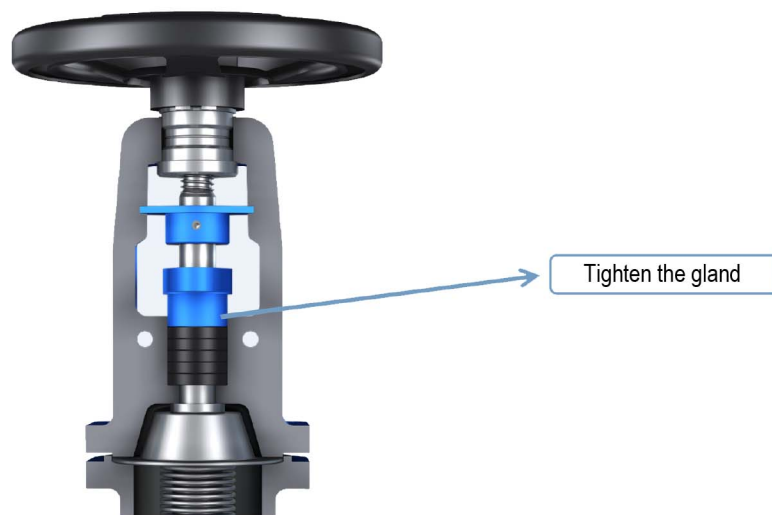

**Leakage on the gland packing means that bellow was damaged. Upper part of the valve should be replaced immediately.**

**For safety assurance, each valve should be controlled and maintenance regularly especially this one which is operated rarely. The frequency of these activities has to be defined by user.**

- Valves in which there is an inflow over the disc are equipped with a balancing disc as shown below. Turning the handwheel to the left raises the balancing disc which results in equalization of upstream and downstream pressure. After pressure equalization the valve can be opened completely. The balancing disc operation is effective only in closed systems. In an open system where it is impossible to equalize pressure the balancing is ineffective. In this case, it is recommended to consider introduction of other structural solutions, e.g. a by-pass.

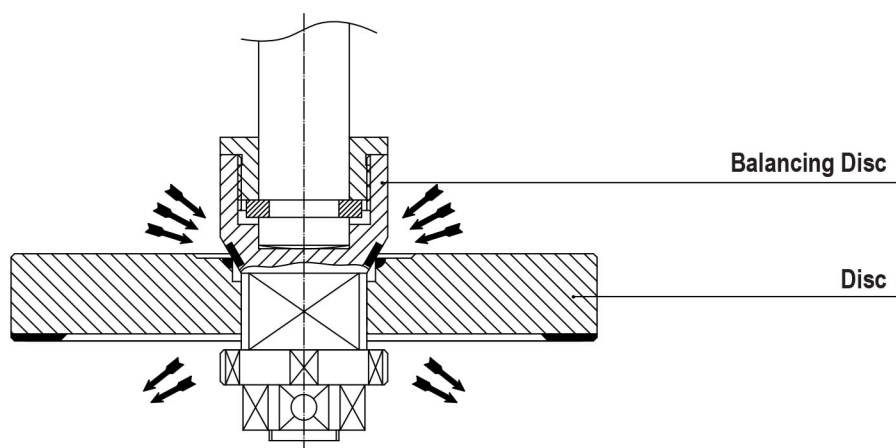

The maximum differential pressure that can apply on both sides of the closing valve (the valve is closed) in valves where there is flow of the plug see in the table below.

NOM PRESSURE (PN)	DIFFERENTIAL PRESSURE (Bar)						
	DN125	DN150	DN200	DN250	DN300	DN350	DN400
PN16	16.0 Bar	16.0 Bar	14.0 Bar	9.0 Bar	6.0 Bar	5.0 Bar	4.0 Bar
PN25	25.0 Bar	21.0 Bar	14.0 Bar	9.0 Bar	6.0 Bar	5.0 Bar	4.0 Bar
PN40	33.0 Bar	21.0 Bar	14.0 Bar	9.0 Bar	6.0 Bar	5.0 Bar	4.0 Bar

**8. SERVICE AND REPAIR**



For safety assurance, each valve should be controlled and maintenance regularly especially this one which is operated rarely. The frequency of these activities has to be defined by user on the basis of working (operating) conditions, nevertheless at least once a month. The stem thread has to be lubricated periodically.

All service and repair jobs should be carried out by authorized staff using suitable tools and original spare parts. Before disassembly of complete valve from the pipeline or before service, the pipeline should be out of operation. During service and repair jobs it is necessary to decrease pressure to 0 bars, valve temperature to ambient temperature and to use personal health protectives in pursuance of existing threat. After valve disassembly it is necessary to replace flange connection gaskets between valve and pipeline.



**Precautions should be taken when touching gasket between body and valve bonnet. The gasket contains stainless steel stripe that may cause injury.**

Every time when valve bonnet was disassembled sealing surface should be cleaned. During assembly it should be applied new gasket of the same type as previously used. Body-bonnet bolt connections should be tighten when the valve is at open position.

The bolts should be tighten evenly and crosswise by torque wrench.

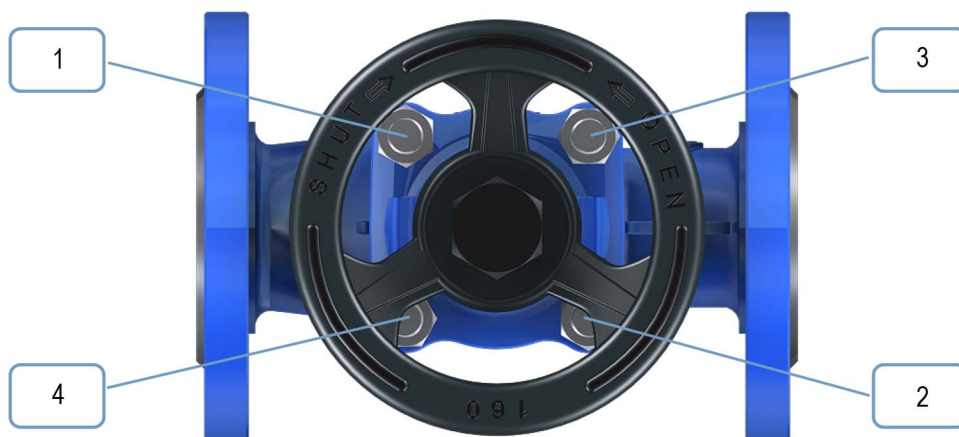



- Before valves re-assembly in the pipeline it is necessary to check valve operation and tightness of all connections. Tightness test should be carried out with water pressure of 1,5 nominal pressure of the valve.

### 9. REASONS OF OPERATING DISTURBANCES AND REMEDY

When seeking of valve malfunction reasons safety rules should be strictly obeyed

Fault	Possible reason	Remedy
Now flow	Valve closed	Open the valve
	Flange dust caps were not removed	Remove dust caps on the flanges
Poor flow	Valve is not open enough	Open the valve
	Dirty filter	Clean or replace the screen
	Clogged pipeline	Check the pipeline
Control difficulties	Dry stem	Grease the stem
	Gland packing tighten too much	Slightly slacken gland nuts. Put attention to keep stuffing box tightness
Stem leakage	Bellow damage	Tighten the gland until tightness will be reached. Replace upper part of the valve as soon as possible.
Seat leakage	Shut off not correct	Tighten the handwheels without any auxiliary tools
	Seat or disc damage	Replace the valve and contact supplier or manufacturer
	Pressure difference too much	Apply valve with balancing disc. Check if the valve was assembled according to arrow direction marked on the valve.
	Medium polluted with solid particles	Clean the valve. Fit strainer before the valve.
Broken connecting flange	Bolts tighten unevenly	Replace the valve with new one

### 10. VALVE SERVICE DISCONTINUITY

All obsolete and dismantled valves must not be disposed with household waste. WIKATÜREN are made of materials which can be re-used and should be delivered to designated recycling centers.

### 11. WARRANTY TERMS

- WIKATÜREN grants quality warranty with assurance for proper operation of its products, providing that assembly of them is done conditions and parameters described in WIKATÜREN catalogue cards. Warranty period is 12 months starting from assembly date, however not longer than 18 months from the sales date.
- Warranty claim does not cover assembly of foreign parts and design changes done by user as well as natural wear.





D-20544 Hamburg, Wendentstrasse 140-142 Germany.